

How to operate an air classifier mill to meet your fine grinding goals

Rob Voorhees Hosokawa Micron Powder Systems

An air classifier mill combines a mechanical impact mill with a dynamic air classifier. Ideal for large-volume continuous processing, the mill is one of today's most widely used grinding machines for reducing dry fine chemicals, food products, and other materials. After describing the air classifier mill's applications, operation, and common variations, this article explains how you can adjust the mill's operation to control the final product's particle size.

Size reduction equipment for processing dry bulk materials is available in several types and can produce coarse, medium, fine, or ultrafine particles. This article concentrates on air classifier mills, which produce fine particles with a nominal top size of 45 microns or finer, depending on the material.

An air classifier mill applies impact grinding and air classification in one step. The mill uses airflow to convey feed material to the mill's grinding chamber, classifies the material into fine and coarse fractions, recirculates the coarse fraction for further grinding, and conveys fine particles out of the mill, all in one continuous operation.

Another benefit of the air classifier mill is its versatility. Not only can the mill grind a wide range of materials, including fine chemicals, minerals, food products, and nutraceuticals, but the mill's large airflow volume makes it well suited to grinding heat-sensitive materials. The incoming airflow can be heated to help dry moist materials

or conditioned to control temperature and humidity for handling heat-sensitive or hygroscopic materials. The mill can be operated in a closed-loop system to allow the conditioned air to be recycled or so that nitrogen or another inert gas can be substituted for air when handling a potentially explosive material.

The air classifier mill can be equipped with wear-protected internal components to handle materials with a Mohs hardness up to 4; such construction is standard for large-capacity mills of 200 or more horsepower that handle minerals or other abrasive materials. Sanitary construction allows the mill to handle pharmaceutical and food-grade products and applications with special cleaning requirements. When it's not economical to replace the air with an inert gas for handling a potentially explosive material, the mill and other equipment in the system can be designed to withstand a 150-psi overpressure.

Unlike size reduction equipment for producing coarser particles, in which screens of various sizes control the final particle size, the air classifier mill has an internal classifier wheel that can be easily adjusted during operation to rotate at higher or lower speed, controlling the particles' final top size. Because classification takes place inside the mill rather than in a separate machine or external operation, the mill is not only relatively compact but provides an economic advantage over grinding mills that discharge to a downstream classification step.

Component and operation details

While air classifier mills are available in many configurations and sizes from several manufacturers, the mills share the same major components and operating characteristics.

Components. A typical air classifier mill — called a *vertical air classifier mill* because of its classifier wheel's orientation — is shown in Figure 1. The mill has a round vertical housing enclosing an internal classifier wheel, which has multiple closely spaced vanes (or blades), and an impact rotor that's mounted in a horizontal position and driven by a motor with from 1 to 600 horsepower, depending on the mill size. Impact tools (usually hammers) are mounted around the edge of a rotor disc located below the classifier wheel; the rotor disc is mounted on a bearing housing with a drive separate from the classifier wheel drive. A ring-shaped liner, typically a *multiple-deflector liner* with vertical grooves, surrounds the rotor disc and hammers. A shroud-and-baffle assembly is usually located above the impact rotor between the liner and the classifier. The space between the shroud-and-baffle assembly and the liner forms the grinding zone, and the space between the assembly and the classifier wheel forms the classification zone.

The mill housing, liner, impact rotor, and shroud-and-baffle assembly together form the grinding chamber. A feed material inlet is located at one side of the grinding chamber, an air inlet is located below the rotor disc, and a combined product-and-air outlet is located at the classifier wheel's discharge side.

Operation. In operation, air enters through the air inlet in the grinding chamber's bottom and flows upward from under the rotor disc, entraining the entering feed material and directing it into the grinding zone. The rotating hammers impact the particles and deflect them into the liner, where the liner's vertical grooves slow the particles' circumferential speed and deflect them back into the hammers' path to maximize the impact force on the particles. The reduced particles are carried upward by the airflow, and the baffles in the shroud-and-baffle assembly help direct the particles into the classification zone. Fine particles pass through the slots between the classifier wheel's vanes and flow with the air out of the product-and-air outlet, while coarse particles that can't pass through the classifier wheel are returned to the grinding zone for further reduction.

More about the drives. Separate drives for the classifier wheel and impact rotor allow you to adjust each component's rotational speed independently. Both can be variable-speed drives, but the impact rotor is usually provided with a fixed-speed drive. The mill in Figure 1 has a coaxial drive assembly, basically consisting of a drive shaft within a drive shaft, which reduces the mill's overall height. (Other drive types are covered in the next section.)

You can also equip the mill with vibration and bearing-temperature sensors to monitor the bearing housing's condition; this allows you to perform maintenance before serious mechanical problems develop.

Figure 1

Vertical air classifier mill

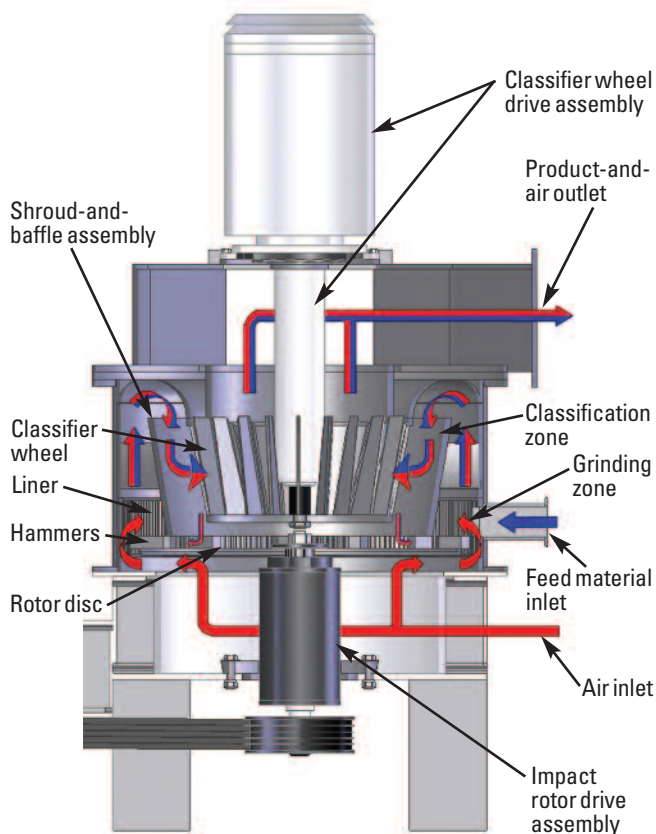

Common classifier mill variations

Other common air classifier mill variations include mills with a horizontal classifier wheel, a combined classifier wheel and rotor drive, a vertical rotor, or an easy-to-clean design. Their operation is similar to that of the vertical air classifier mill, but they're configured differently.

Horizontal wheel. While in principle the horizontal-wheel classifier mill operates the same way as the vertical mill, the horizontal orientation of its classifier wheel doesn't allow the use of a shroud-and-baffle assembly to separate the grinding zone from the classification zone. Instead, the two zones are separated by extending the housing to allow room for particles to circulate during classification, as shown in Figure 2a. This makes the mill much taller than the vertical mill, but allows it to be closely coupled with a cyclone or filter-receiver when required. This mill's classifier wheel and impact rotor have independent drives, and the mill can handle the same grinding applications as the vertical mill.

Combined drive. In this classifier mill, as shown in Figure 2b, the classifier wheel and rotor disc are mounted on one shaft and rotate at the same speed. As a result, the mill is smaller, has a lower purchase cost, and requires less installed horsepower than the vertical mill. However, the ap-

plication range the mill can handle and its particle size adjustment range are limited.

Vertical rotor. The vertical-rotor classifier mill has a vertically oriented impact rotor and rotor discs, as shown in Figure 2c, the opposite of the vertical mill's configuration (Figure 1). The two rotor discs with hammers in Figure 2c provide primary and secondary impact. This mill's benefit when compared with the other mills is that the classifier wheel rejects coarse particles and ejects them from the mill rather than recirculating them to grinding zone; this removes hard, ungrindable particles from the grinding chamber, reducing the mill's power consumption and component wear and removing impurities that can reduce the final product's color quality and brightness. The mill has independent drives for the classifier wheel and impact rotor and can handle a similar range of grinding applications as the vertical mill.

Easy to clean. The easy-to-clean classifier mill has an external chamber outside the grinding chamber, as shown in Fig-

ure 2d. This chamber acts as a vessel so the operator can clean the mill while containing the effluent inside the chamber; a ball valve is typically installed in the chamber's bottom to serve as a drain. The external chamber also provides a tangential air inlet (rather than an air inlet under the rotor disc) that simplifies access to the mill's internal components for cleaning. The mill liner isn't mechanically attached to the housing, allowing it and other internal components to be easily removed for cleaning. The mill can handle the same applications as the vertical mill and is ideal for those applications requiring frequent mill cleaning.

Adjusting the mill's operation to change your final particle size

You can equip the air classifier mill with different components and adjust their operation to achieve your final product's desired top particle size and particle size distribution.

Internal components. While the classifier wheel rotational speed and airflow provide primary control of your final product's top particle size, you can change the mill's

Figure 2

Common classifier mill variations

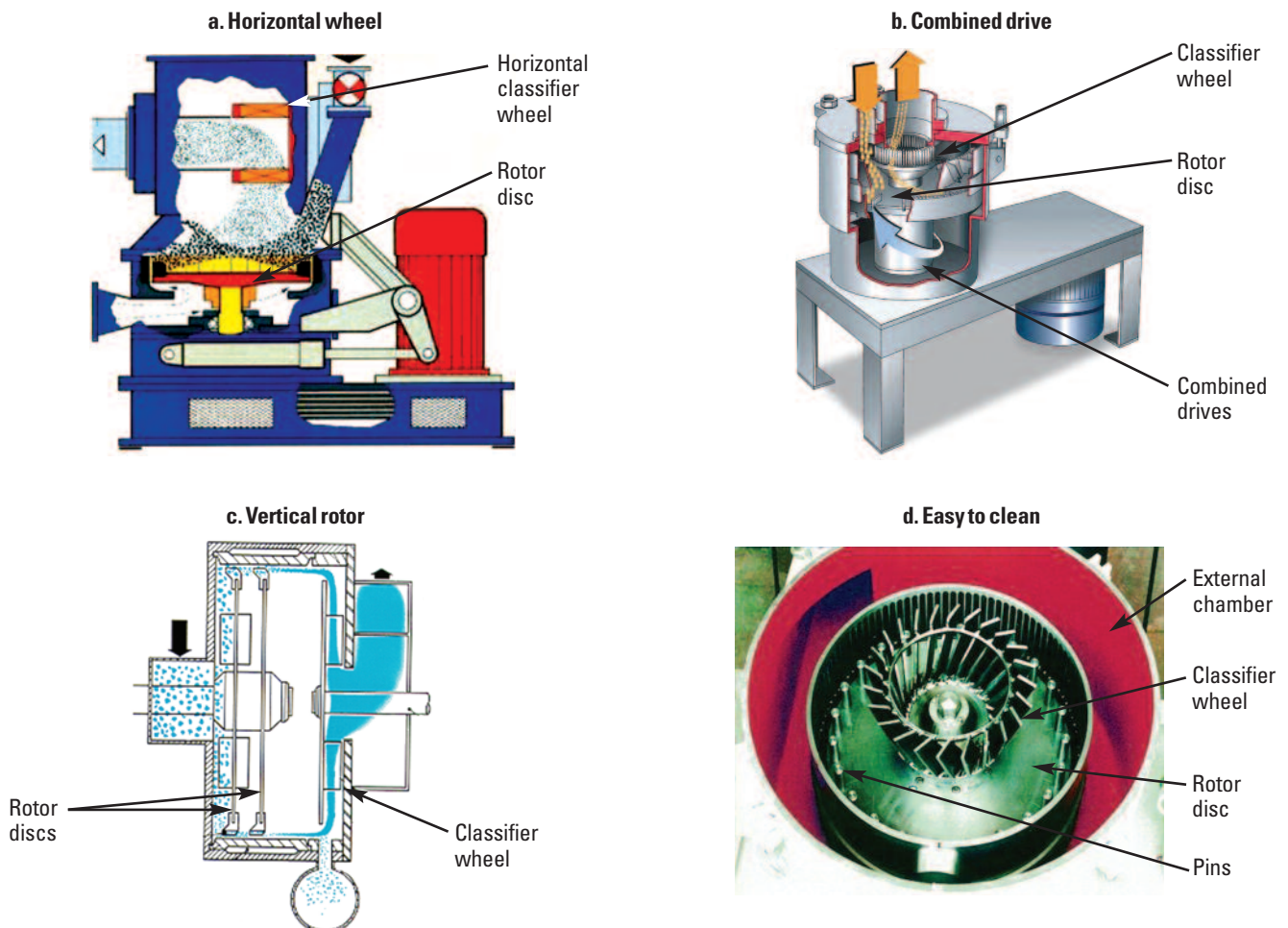

liner and impact tools or adjust them to control your final particle size *distribution*.

Liner configuration: To reduce fines generation or yield a final product with a narrower particle size distribution, you can switch from the standard multiple-deflector liner to a smooth liner. The smooth liner reduces the impact force the hammers apply to the particles, yielding a narrow particle size distribution with minimal fines.

To reduce fines generation or yield a final product with a narrower particle size distribution, you can switch from the standard multiple-deflector liner to a smooth liner.

Impact tool type and peripheral speed: The impact tool type affects the impact force imparted to the particles, which affects your final product's particle size distribution. The standard tool, a hammer with a flat face, imparts a large impact force on the particles to produce a relatively small final size distribution. To reduce the impact force on the particles and provide a coarser particle size distribution with minimal fines, you can replace the hammers with round pins (Figure 2d).

The higher the impact rotor's rotational speed — and, in turn, the hammer or pin tip speed — the finer your final particle size distribution will be. Reducing the impact rotor's speed will also minimize fines generation and produce a coarser particle size distribution.

Classifier wheel speed. To understand how the classifier wheel's rotational speed affects classification, let's examine what happens to one particle as it approaches the wheel. Two forces are at work on the particle: a drag (centripetal) force generated by airflow traveling toward the wheel and a mass (centrifugal) force generated by the wheel's rotation.

When these two forces are balanced for a specific particle mass, the particle has a 50/50 chance of being accepted by the classifier wheel (flowing through it with the airflow to the product-and-air outlet) or rejected (directed back toward the grinding zone). So by varying the drag and mass forces in the mill, you can control the classification *cut point* — that is, the point at which coarse particles are separated from fine particles. The cut point and, thus, the final product's top particle size will vary with the square of the classifier wheel's tip speed, so making a small change in the wheel's rotation speed will have a large effect on your final particle size. [**Editor's note:** For more detailed information about the effects of drag and mass force on air classification, contact the author.]

Airflow volume and velocity. While you can adjust the airflow volume through the mill to change the final product's particle size, keeping the airflow volume constant is more practical for achieving consistent, reproducible product quality. As a result, the classifier wheel's rotational speed is the main factor in adjusting the final product's particle size. The classifier wheel is available in various heights with different numbers of vanes (or blades); you can select these features to vary the amount of surface area on the wheel and thus control the air velocity through it. This allows the airflow volume through the mill to remain constant while the air velocity through the wheel is controlled by the wheel's size, number of vanes, and rotational speed to improve the mill's classifying performance. You can see the relationship of airflow volume and classifier wheel rotational speed to the final product's particle size in Table I.

Example air classifier mill system

Figure 3 shows a vertical air classifier mill installed in a closed-loop system. The system uses an inert gas, nitrogen, rather than air to safely handle a potentially explosive material, and its closed-loop design allows the expensive inert gas to be recycled through the mill. (The closed-loop arrangement can also be used to recycle conditioned air to save energy.)

In this system, a feeder meters material through a rotary airlock valve to the mill. Coarse particles rejected by the mill's classifier wheel are recycled within the mill, while fine particles entrained in the gas stream flow through the wheel and exit the product-and-air outlet. The particles flow to a filter-receiver where fine particles are separated from the gas stream and then discharged through a rotary valve to a downstream process. The gas flows through a safety filter and then to a blower, which generates the required gas volume for the system. The recycled gas passes through a heat exchanger, and additional nitrogen is added to the gas stream to maintain the system's required oxygen level before it passes through another safety filter and flows back to the mill. The valve at the far right bleeds off excess gas to control the closed-loop system's internal pressure.

Table I

Influence of airflow volume and classifier wheel speed on particle size

Airflow volume	Classifier wheel rotational speed	Final product particle size
Constant	Constant	No change
Constant	Higher	Finer
Constant	Lower	Coarser
Higher	Constant	Coarser
Lower	Constant	Finer

Figure 3

Closed-loop air classifier mill system

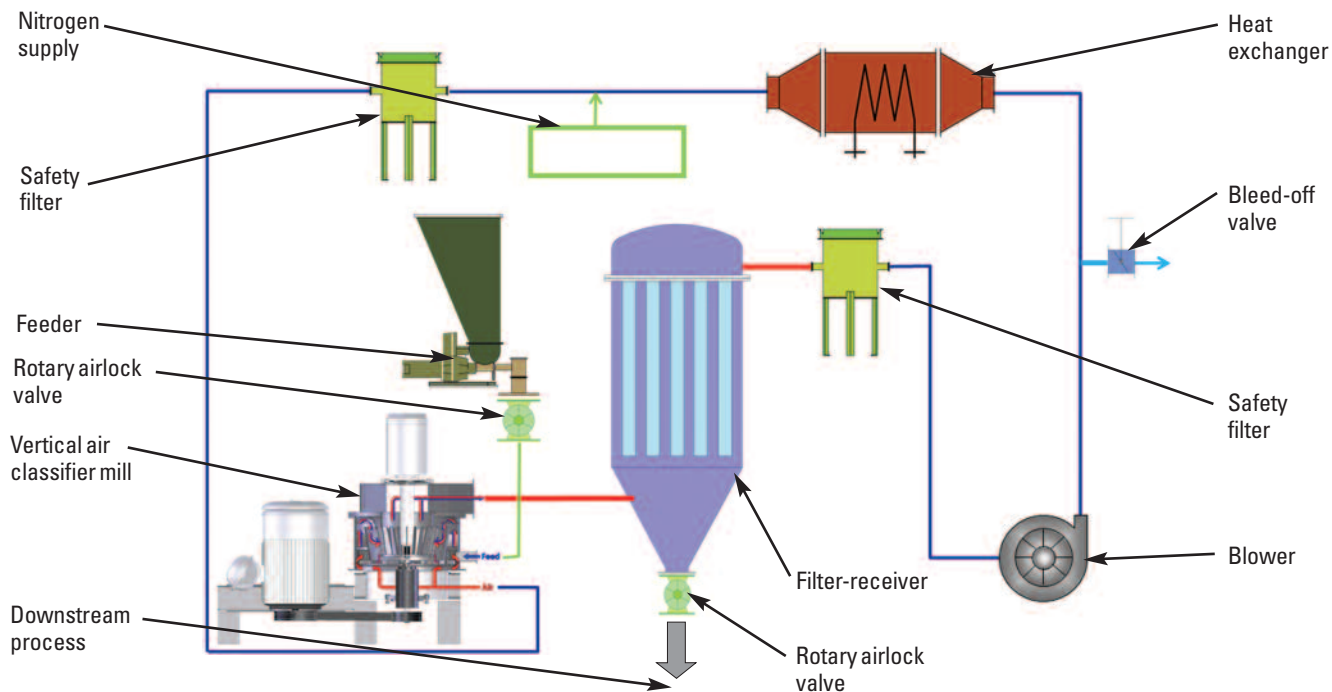

Some selection advice

To select an air classifier mill for your application, you'll need to share some basic information about your feed material and your final product requirements with mill suppliers. The information includes your feed material's particle size and other characteristics (such as particle shape, bulk density, cohesiveness, Mohs hardness, moisture content, friability, and softening or melting point) and your final product's required particle size distribution.

This information will help a supplier guide you toward the right mill and the right system design for your fine-grinding application. Typically, you'll need to run tests with your material in a pilot-scale mill system. The results will not only help you determine which mill can best handle your application, but will provide operating guidance to help you achieve top grinding and classification results once the equipment is installed in your plant. **PBE**

For further reading

Find more information on fine grinding in articles listed under "Size reduction" in *Powder and Bulk Engineering's* article index (in the December 2012 issue and at *PBE's* website, www.powderbulk.com) and in books available on the website at the *PBE* Bookstore. You can also purchase copies of past *PBE* articles at www.powderbulk.com.

Rob Voorhees is vice president and general manager of *Hosokawa Micron Powder Systems*, 10 Chatham Road, Summit, NJ 07901; 908-277-9261, fax 908-273-6344 (rvoorhees@hmps.hosokawa.com, www.hmicronpowder.com). He holds a BA in industrial technology from Montclair State University in New Jersey and has 33 years experience in bulk materials processing technologies.