



Valves

Handling the world's dry bulk solids®

VORTEX® QUANTUM® ORIFICE GATE™

The patented Quantum® Series Orifice Gate™ is specifically designed to handle dry bulk solids in gravity flow, dilute phase, or vacuum conveying systems. A full flow orifice provides unrestricted conveying of material with no disk or ledges to impede flow or cause material bridging. The gate seat and live-loaded seals are shielded from blast abrasion by a metal insert, which provides a smooth bore through the valve improving performance and decreasing any pressure drop across the orifice. By design, the valve “self cleans” material from the seat on each stroke of the valve blade, improving overall seat life. The Quantum® Series Orifice Gate™ is designed to eliminate problems, increasing production, while decreasing labor and equipment costs.

Vortex® Quantum® Series Orifice Gate™ Features

- Self-Cleaning Action, No Material Build-Up
- Smooth, Unobstructed Bore for Unrestricted Flow of Material
- Seal Protected from Abrasion
- Accurate Metering of Material with Optional Metering Controls
- Easy Installation and Maintenance
- Air Cylinder Model Includes Magnetic Piston



Valve Specifications

Size/Bore Options	2" to 14" Diameters
Media	Powder, Pellets, Granulars
Connection Options	SVC Standard Stud Pattern, ANSI, DIN, JIS, and Custom Flanges available
Media Temperature	Up to 180°F continuous to 250°F intermittent service, Modifications allow up to 400°F continuous to 450°F intermittent service
Media Pressure	Up to 15 psig, -0.1 MPa +0.1 MPa, 1 barg, depending on size
Metal Construction Options	304 or 316L Stainless Steel, Aluminium, and/or Carbon Steel
Seal/Seat Material Options	Nylon, PET, UHMW, Glass Filled Teflon, Rubber, and/or Silicon
Drive/Actuation Options	Double Acting Air Cylinder and Solenoid Operated Air Control Valve, Electric Actuator, Hand Crank, Chain Wheel, Hydraulic
Position Confirmation	Magnetic Reed Switch, Proximity Switch, or Mechanical Switch
Compliance/Approvals	CE, ATEX, FDA
Industry Use	Plastics, Petrochemicals, Chemicals, Foods, Minerals, Textiles, Agriculture

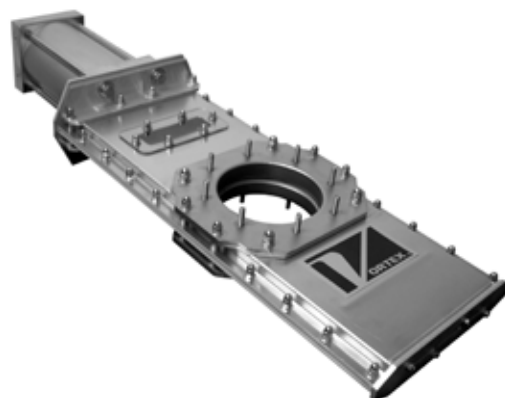

Patent No. 7464913

Application Specific Modifications

G	Valve constructed of painted mild steel body and mounting flange with 304 or 316L stainless steel material contact.
H	Valve constructed of aluminium body and mounting flange with aluminium and stainless steel material contact.
F	Valve constructed of aluminium body with 304 or 316L stainless steel mounting flange and material contact.
J	Valve constructed of 304 stainless steel body and mounting flange with 304 or 316L stainless steel material contact.
HT3	Modifications are made allowing 250°F continuous to 300°F intermittent service.
HT4	Modifications are made allowing up to 400°F continuous to 450°F intermittent service.
WS1	Slide blade is electro-polished. Polyethylene Terephthalate (PET) pressure plate seals replace Nylon.