

Roto-Louvre® Dryer or Cooler

Roto-Louvre® is an FMC Technologies exclusive Processor for precise control and gentle handling of bulk materials.

FMC Roto-Louvre® Systems are custom engineered to efficiently dry and/or cool a wide variety of products in Food, Pharmaceutical, Chemical, Mineral and Industrial applications.

**We put you first.
And keep you ahead.**

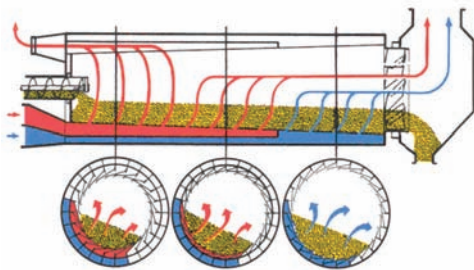

Pictured above: Dryer / Cooler

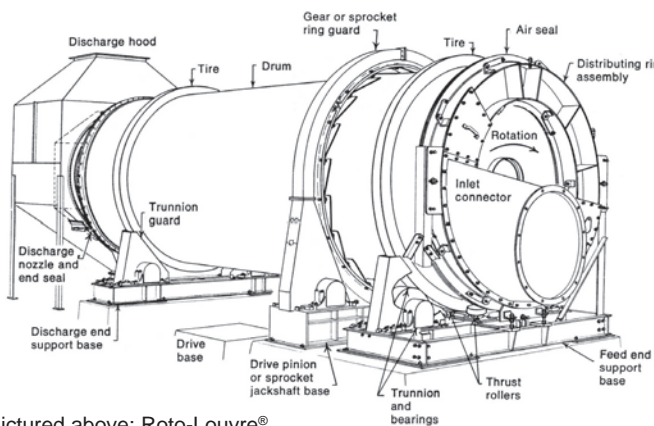

Pictured above: Roto-Louvre®

Sample Products

Chemicals	Industrial	Food	Minerals	Pharmaceutical
Ammonium Sulfate	Gypsum	Cocoa, Coffee Beans	Coke	Ingredients
Dicalcium Phosphate	Lead	Cereal	Coal	
Sodium Nitrate	Sand	Rice	Gypsum	
		Sugar		

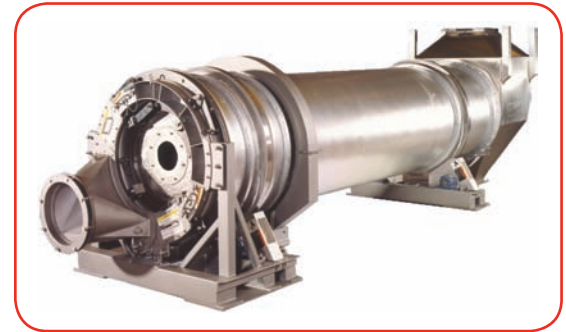

Pictured above: Roto-Louvre®

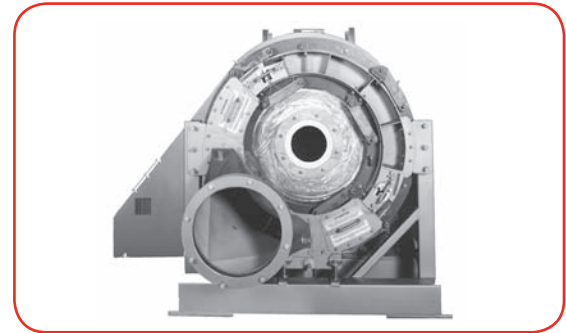

Pictured above: Feed / Inlet

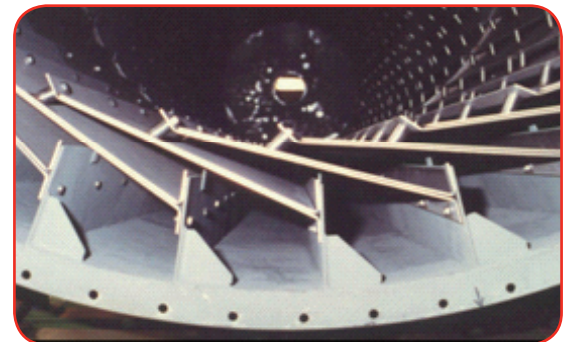

Pictured above: Louvres

Features and Benefits:

- Precise Control
- Gentle Handling
- Compact Size
- Highest Efficiency
- Multiple Heat Zones
- Uniform Drying
- No Over Heating
- Pristine Processing
- Complete Systems

Contact FMC Technologies for Innovative Solutions to Materials Processing

400 Highpoint Drive | Chalfont PA 18914 | P: 215 822 4300 | F: 215 822 4520 | E: info.mhs@fmcti.com

www.fmcmaterialhandling.com