



Raymond® Imp™ Mills



Air Preheater Company
Raymond Operations

Raymond® Imp™ Mills

Low Cost Grinding of a Wide Variety of Materials

The Raymond Series 3 Imp Mill is a versatile and dependable high speed airswept swing hammer impact mill designed for fine and medium grinding of soft non-metallic minerals, coals, various chemical compounds, food products and other materials.

For nearly 100 years Raymond Imp Mills have served the processing needs of many industries. Almost any solid material with a nominal 1 inch top size that is softer than 2 on the Mohs Scale can be effectively pulverized in the Raymond Imp Mill to a fineness from 1,000 microns to as little as 5 microns.

Raymond Series 3 Imp Mills are available in six sizes, with capacities from 250 to 40,000 lb/hr and feature heavy-duty all-welded plate construction designed to provide the kind of 24-hour-a-day dependability and long life on which our customers have come to rely.

Applications

Standard Imp Mill Systems

The Raymond Series 3 Imp Mill system is the ideal solution to many size reduction applications requiring pulverizing of a variety of materials. A typical system consists of the Imp Mill with either rotary or vibratory feeder, elevated in-stream classifier, system fan and cyclone. This basic configuration has proven itself the world over.

Imp Mill System with Flash Drying

Many materials contain a certain amount of free water in the form of moisture that must be removed in order to increase the value of the pulverized material and to allow it to be handled more efficiently.

The Raymond Imp Mill system has the flexibility needed to allow it to both pulverize and dry the material simultaneously.

The Imp Mill system with flash drying requires a source of heated air which can be in the form of a fired air heater or waste heat source. The heated air is used to flash dry the material as it is pulverized and swept from the mill. Depending on the initial moisture content of the feed, a portion of the dried product may be combined with the moist feed material in a double paddle mixer. This "conditioned" feed is easier to handle and is more efficiently dried and pulverized. A vent is provided to remove a portion of the moist air and the balance of the warm air is returned to the system where it is mixed with fresh, warm air coming from the air heater.

Imp Mill System with Flash Calcining

In addition to free moisture, some materials, such as gypsum, contain chemically-bound water, which must be removed in order to change the physical characteristics of the material. This process, known as calcining, can be easily accomplished with a Raymond Imp Mill system.

Essentially similar to the Imp Mill system with flash drying, the Imp Mill system with flash calcining is provided with a number of special features which make it suitable for the higher temperatures involved. Our experience in the processing of gypsum, by-product gypsum and waste wallboard provides our customers with a single source of equipment supply for processing gypsum and the manufacturing of gypsum wallboard stucco.

Imp Mill Flash Calcining System

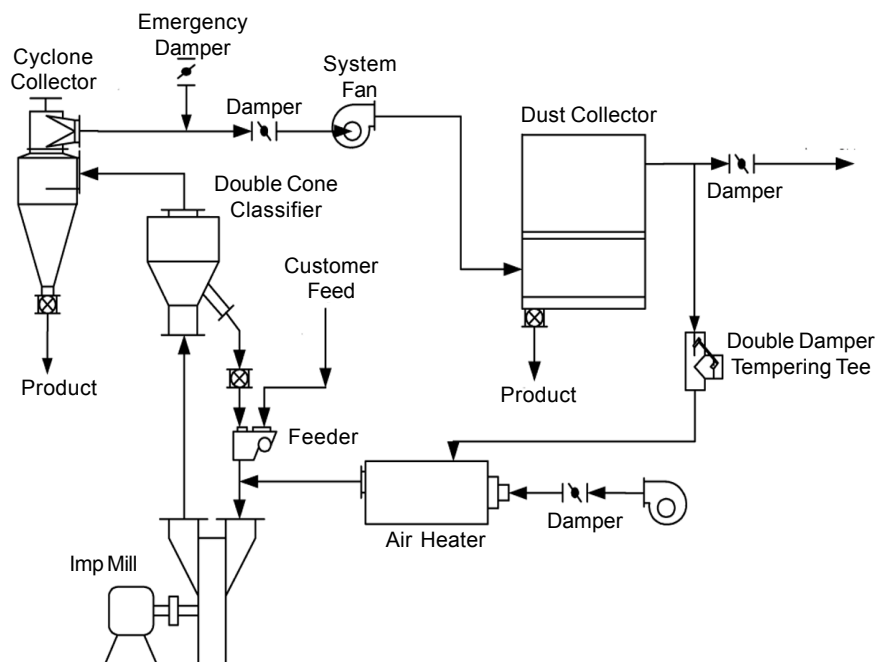

Raymond® Imp™ Mills

Construction Features

Imp® Mill Construction Features

Heavy-duty construction - all housings and bases feature heavy gauge steel plate construction that provides structural rigidity, long service life and the mass required to ensure smooth performance.

Housing liners - mill housings fitted with bolt-on replaceable liners, available in a variety of alloys to suite the specific application and ensure long life.

Bearings - cast iron split pillow block with self-aligning spherical roller bearings. For the most severe conditions either heat slingers for air cooled bearings or a circulating cooling system is provided.

Housing - split housing design, with access doors on larger size mills, provides quick access to mill interior reducing maintenance costs and lost production.

Hammer disks/rotor assembly - constructed of heavy-gauge steel plate with abrasion resistant liners, mounted on a hot-rolled steel shaft and electronically balanced at high speed for smooth operation, long life and the inertia required to absorb heavy impact.

Hammers - available in various shapes and materials to suite specific applications, assures maximum grinding action and efficiency.

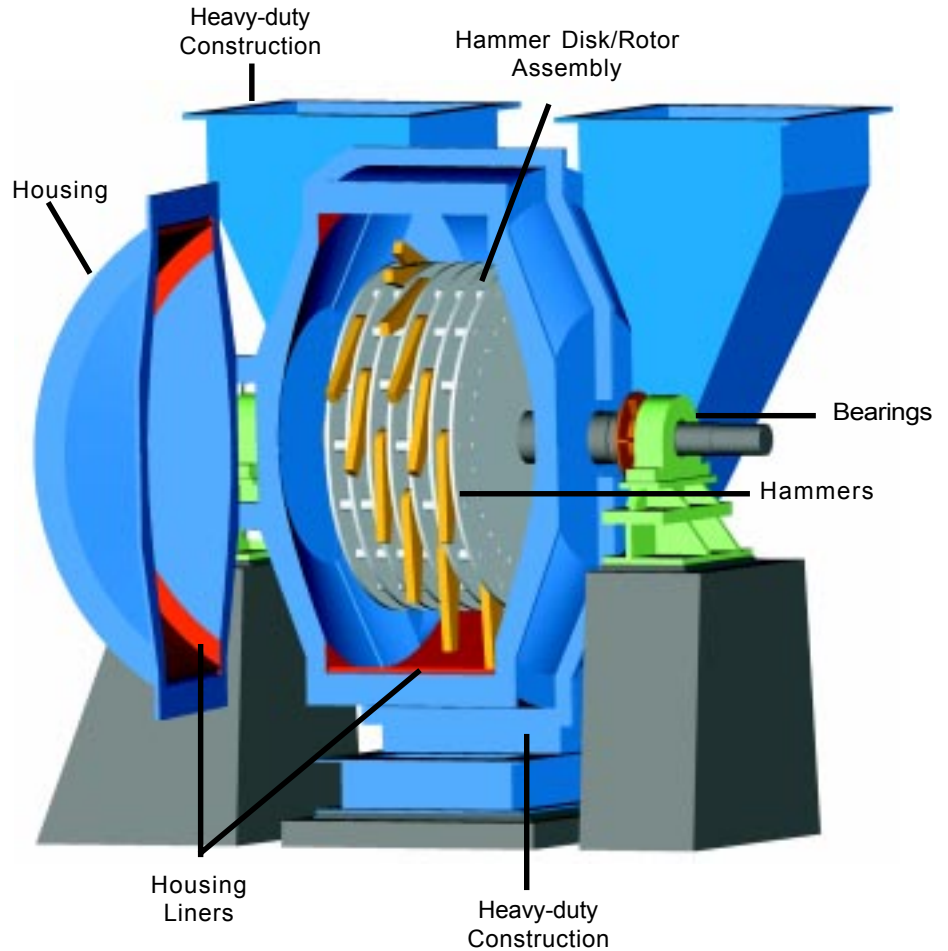

Airflow and Power Requirements for Raymond® Imp Mill Systems

Mill Size	Nominal Airflow - *		Fan Power		Mill Power-min		Mill Power-max		Turbine Power	
	acfm	m ³ /h	hp	kW	hp	kW	hp	kW	hp	kW
13	1,000	1,700	7.5	5.5	20	15	25	19	5	4
43	3,000	5,100	20	15	30	22	75	55	15	11
53	6,000	10,200	40	30	50	37	150	110	25	18
63	12,000	20,400	75	55	125	93	250	185	50	37
83	25,000	42,500	150	110	300	223	500	375	100	75
103	36,000	61,200	250	185	400	315	900	900	125	90

* Airflow for many applications will exceed nominal values.

Raymond® Imp™ Mills

System Flexibility and Options

Because the Raymond Series 3 Imp Mill system can be configured in a number of different ways, it is capable of pulverizing, classifying, drying, calcining and beneficiating various materials.

Hammer Configuration

A variety of hammer types are available to ensure maximum flexibility in the Raymond Imp Mill. By varying the number and position of the hammers on the hammer disks, a rough degree of fineness variation can be obtained, which is later “fine tuned” by adjusting the setting of the classifier.

Materials of Construction

A selection of materials of construction is available to ensure long life and efficient operation with a wide variety of abrasive or corrosive materials, or for applications that require special treatment. These materials can be incorporated in the Raymond Imp Mill's housing, shaft, housing liner, hammers and hammer disks, as well as ductwork and classifiers. They include abrasion resistant steels, stainless and other corrosion and heat resistant alloys, special overlays, coatings and liners.

Product Collection

Raymond supplies high efficiency cyclone collectors for its Imp Mill systems to separate the entrained pulverized solid particles from the airstream. Air exiting the cyclone is normally recirculated to the mill, with a small portion vented to a secondary collector, usually of the fabric filter type, or the full air stream may be directed to the secondary collector.

Integral and Instream Classifiers

When operated in closed circuit with an elevated instream classifier, oversized particles are continuously re-

turned to the grinding chamber until they are reduced to the required fineness. This is not only provides good particle size control, it also improves the mill's grinding efficiency.

A variety of different types of classifiers, which can meet the requirement of almost any application, are available for the Raymond Imp Mill system.

- Double cone classifier is a static separator (no revolving parts) which utilizes adjustable vanes to impart a controlled swirl to the material-laden air as it flows through the classifier. For those applications which require fineness of no greater than 85% passing 200 mesh, and where the system is not required to provide a wide variety of particle size specification, the double cone classifier is an excellent choice.

- Twin cyclone classifier is used primarily on Imp Mill systems with flash drying, features two cyclones in parallel circuit, one of which is mounted slightly higher than the other. This type of classifier increases the overall efficiency of the Imp Mill flash drying system by reducing the circulating load and allowing operation at a lower exit temperature for both air and product. It is ideal for those applications requiring uniformity of both particle size and dryness.

Whizzer classifiers are available with single or double banks of whizzer blades. Both types utilize small horizontal blades mounted between disks which are affixed to a vertical rotating shaft.

The single whizzer classifier is ideal for those applications requiring a wide range of finenesses, with fineness no

greater than 85% passing 200 mesh. The double whizzer classifier is similar to the single model with the exception that it utilizes two banks of whizzer blades. It is ideal for those applications requiring finenesses to 99.9% minus 325 mesh. Both the single and double whizzer classifier are typically provided with a variable speed motor of 7½ hp to 30 hp, depending on classifier size.

- Top drive whizzer classifier for both the single and double whizzer classifiers are available for applications requiring large horsepower motors, where operating temperatures are high, or where the interior parts of the classifier must be made of special materials.

- Turbine classifiers feature a high speed rotating turbine, or rotor, which resembles a squirrel cage fan wheel. This rotor contains many thin vertical blades through which the material-laden air is drawn in a direction opposite what would be expected in a centrifugal fan wheel. By balancing the centripetal force thus created by the system fan with the centrifugal force generated by the rotating turbine, a very narrow cut point can be established. The turbine classifier is most advantageous in applications requiring precise particle size control and fine to ultra-fine particle sizes, typically from 99.9% passing 325 mesh to as fine as 99.9% passing 5 microns. They are typically supplied with a 7½ hp to 125 hp variable speed motor, depending on classifier size.

Raymond® Imp™ Mills

Performance Characteristics

Nominal Capacity of Raymond® Imp™ Mills-stph

Material	Moisture		Fineness		Mill Size					
	Initial - %	Final - %	% Passing	Mesh	13	43	53	63	83	103
Aluminum Triphosphate	20	0.5	75	325	0.6	1.8	3.6	5.9	12	18
Bark	57	45	90	8	0.5	1.4	2.8	4.5	9.0	14
Calcium Carbonate	30	0.5	99	325	0.5	1.5	3.0	5.0	10	15
Clay	40	1	99.9	325	0.3	0.8	1.5	2.5	5.0	7.5
Clay, Ball	25	2	90	200	1.0	2.7	5.4	9.0	18	27
Coal	8	1	99	20	0.3	1.0	2.0	3.0	6.0	9.0
Corn, Cooked	40	12	85	200	0.3	0.7	1.5	3.0	6.0	9.0
Gluten, Vital Wheat	67	10	95	60	-	-	0.2	0.3	0.5	1.0
Gypsum (FGD calcining)	21*	5.5*	75	325	1.3	3.5	6.7	13	28	40
Gypsum (Natural calcining)	21*	5.0*	70	325	1.2	3.1	6.0	12	26	36
Gypsum (Waste)	-	-	90	100	0.8	1.7	3.8	7.5	15	23
Insecticides	-	-	90	325	0.8	2.0	4.0	6.9	14	21
Kaolin Clay	15	1	99.9	325	1.6	4.5	9.0	15	30	45
Lignite	40	22	99.5	20	0.7	2.0	4.0	6.5	13	20
Lime Products	17	1	95	200	1.0	3.0	6.0	10	20	30
Litharge	-	-	99	200	0.4	1.3	2.5	4.2	9.2	12
Peat	50	8.0	95	100	0.2	0.3	0.7	1.4	2.7	4.0
Phosphate Compounds	-	-	75	270	1.3	3.1	7.2	12	24	36
Pigments	-	-	95	325	0.2	0.5	1.0	1.7	3.4	5.1
Soy Flour	-	-	95	100	0.8	2.0	4.0	7.0	14	21
Soy Protein	73	8.0	50	100	0.1	0.2	0.4	0.8	1.5	2.3
Starch	-	-	99	200	1.0	2.0	4.5	9.0	18	27
Stearate Compounds	60	0.1	95	325	0.1	0.2	0.3	0.5	1.0	1.5
Sulfur Compounds	-	-	98	100	0.4	0.8	1.7	3.4	6.8	10
Sunflower Hulls	15	7.0	25	50	0.5	1.5	3.0	5.0	10	15
Talc	15	0.2	99.5	325	0.7	1.8	3.6	6.0	12	18
Tri-Calcium Phosphates	50	0.5	99	325	0.1	0.3	0.6	1.0	2.0	3.0
Wood Waste	55	30	85	10	0.5	1.5	3.0	5.0	10	15

*Total moistures at maximum airflow.

Air Preheater Company Raymond Operations

General Offices

ALSTOM Power, Inc.

Air Preheater Co., Raymond Operations
4525 Weaver Parkway, Suite 250
Warrenville, Illinois 60555 USA
Toll Free: 877.661.5509
Tel: 630.393.1000
Fax: 630.393.1001
E-mail: info@airpreheatercompany.com
Website: www.airpreheatercompany.com

Raymond Laboratory Facility

2151 Fisher Drive
Naperville, Illinois 60563
Tel: 630.369.3700
Fax: 630.983.6750

Sales Offices

Stamford, CT

Tel: 203.348.1791
Fax: 203.348.1792

Atlanta, GA

Tel: 770.650.8888
Fax: 770.650.8430

Sycamore, IL

Tel/Fax: 815 .899.8057

St. Louis, MO

Tel: 314.770.1677
Fax: 314.291.1734

Katowice, Poland (Europe)

Tel: +011.4.322.583.583x231
Fax: +011.48.322.599.570

Vinhedo (Sao Paulo) Brazil

Tel/Fax: +011.55.19.3876.3526

Sales Representatives

Asia

Siam Energy Group Co., Ltd.
Tel/Fax: +662.758.8595

California

Krupa Sales
Tel: 925.933.8225
Fax: 925.934.5989

